

Please check the examination details below before entering your candidate information

Candidate surname

Other names

Centre Number

Candidate Number

--	--	--	--	--

--	--	--	--

Pearson Edexcel International GCSE

Time 2 hours

Paper
reference

4MA1/2FR

Mathematics A

PAPER 2FR

Foundation Tier



You must have: Ruler graduated in centimetres and millimetres, protractor, pair of compasses, pen, HB pencil, eraser, calculator. Tracing paper may be used.

Total Marks

Instructions

- Use **black** ink or ball-point pen.
- **Fill in the boxes** at the top of this page with your name, centre number and candidate number.
- Answer **all** questions.
- Without sufficient working, correct answers may be awarded no marks.
- Answer the questions in the spaces provided
– *there may be more space than you need.*
- **Calculators may be used.**
- You must **NOT** write anything on the formulae page.
Anything you write on the formulae page will gain NO credit.

Information

- The total mark for this paper is 100.
- The marks for **each** question are shown in brackets
– *use this as a guide as to how much time to spend on each question.*

Advice

- Read each question carefully before you start to answer it.
- Check your answers if you have time at the end.

Turn over ►

P68728A

©2022 Pearson Education Ltd.

L:1/1/1/



P 6 8 7 2 8 A 0 1 2 8



Pearson

International GCSE Mathematics
Formulae sheet – Foundation Tier

Area of trapezium = $\frac{1}{2}(a + b)h$

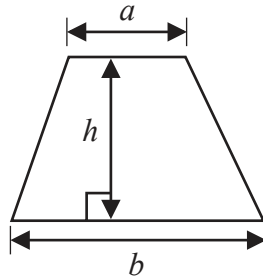

Volume of prism = area of cross section \times length

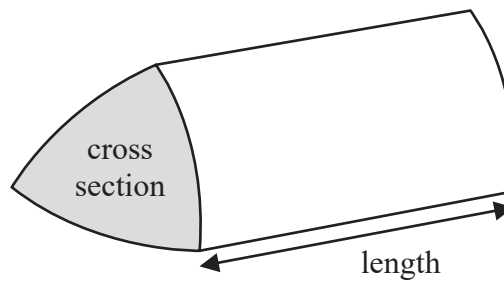

Volume of cylinder = $\pi r^2 h$

Curved surface area of cylinder = $2\pi r h$

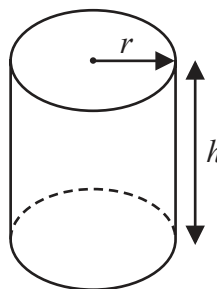

DO NOT WRITE IN THIS AREA

DO NOT WRITE IN THIS AREA

DO NOT WRITE IN THIS AREA



Answer ALL TWENTY SIX questions.

Write your answers in the spaces provided.

You must write down all the stages in your working.

- 1 The table gives the total area of forest in each of six countries.

Country	Area of forest (km ²)
South Africa	92 410
Denmark	5 871
El Salvador	2 870
Bahamas	5 150
Jamaica	3 371
Syria	4 910

- (a) Which of these six countries has the least total area of forest?

.....
(1)

- (b) Write down the value of the 4 in 92 410

.....
(1)

Two of the six countries each have a total area of forest of 5000 km² when rounded to the nearest thousand.

- (c) Write down the name of the two countries.

..... and
(1)

- (d) Write the number 3371 in words.

.....
(1)

(Total for Question 1 is 4 marks)



- 2 The diagram shows three points, A , B and C , on a grid.

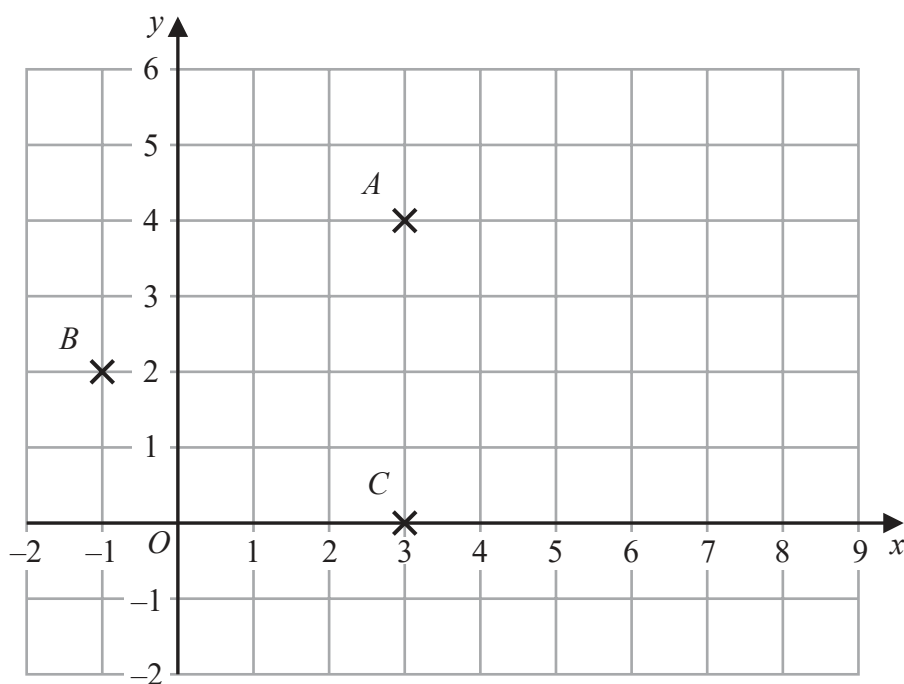

- (a) Write down the coordinates of

(i) point A

(.....,) (2)

(ii) point B

(.....,) (2)

D is the point such that $ABCD$ is a rhombus.

- (b) On the grid, mark with a cross (\times) the point D
Label this point D

(1)

- (c) Find the coordinates of the midpoint of AB

(.....,) (2)

(Total for Question 2 is 5 marks)



- 3 (a) Write down the mathematical name of this 3-D shape.

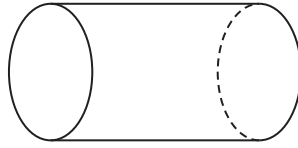

.....
(1)

Here is a solid prism.

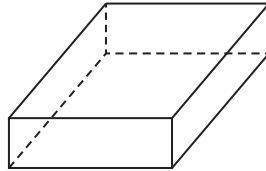

- (b) How many edges has the prism?

.....
(1)

(Total for Question 3 is 2 marks)

- 4 Here are the salaries, in thousands of dollars, of seven people.

21 28 29 32 34 34 39

- (a) Find the mode of the salaries.

..... thousand dollars
(1)

- (b) Find the range of the salaries.

..... thousand dollars
(1)

(Total for Question 4 is 2 marks)



5 (a) Work out $\frac{4}{5}$ of 80

.....
(1)

(b) Write $\frac{9}{20}$ as a decimal.

.....
(1)

Here are four fractions.

$$\frac{1}{3} \quad \frac{2}{9} \quad \frac{3}{8} \quad \frac{4}{11}$$

When written as a decimal, **one** of these fractions will give a terminating decimal.

(c) Write down the fraction.

.....
(1)

(d) Write $\frac{11}{4}$ as a mixed number in its simplest form.

.....
(1)

Here is a list of four words that can be used to describe numbers.

cube	square	prime	negative
------	--------	-------	----------

(e) Use the word from the list to complete the sentence below correctly.

25 is a number

(1)

(Total for Question 5 is 5 marks)



DO NOT WRITE IN THIS AREA

DO NOT WRITE IN THIS AREA

DO NOT WRITE IN THIS AREA

6 Here is a square.



Diagram **NOT**
accurately drawn

The perimeter of the square is 24 cm.

The shaded rectangle below is made from 4 of these squares.



Diagram **NOT**
accurately drawn

Work out the perimeter of the shaded rectangle.

..... cm

(Total for Question 6 is 3 marks)



P 6 8 7 2 8 A 0 7 2 8

7 (a) Write the ratio 42 : 96 in its simplest form.

.....
(2)

There are only apples and pears in a fruit basket so that
the number of apples : the number of pears = 4 : 11

(b) What fraction of the fruit in the basket is pears?

.....
(1)

(Total for Question 7 is 3 marks)

8 Danielle is going to print some business cards.

She uses this rule to work out the total cost, in euros, of printing the business cards.

$$\text{Total cost} = \text{price per card} \times \text{number of cards} + \text{fixed fee}$$

price per card = 0.14 euros

fixed fee = 25 euros

Danielle is going to print 350 business cards.

Work out the total cost of printing the business cards.

..... euros

(Total for Question 8 is 3 marks)



DO NOT WRITE IN THIS AREA

DO NOT WRITE IN THIS AREA

DO NOT WRITE IN THIS AREA

9 Here is a quadrilateral.

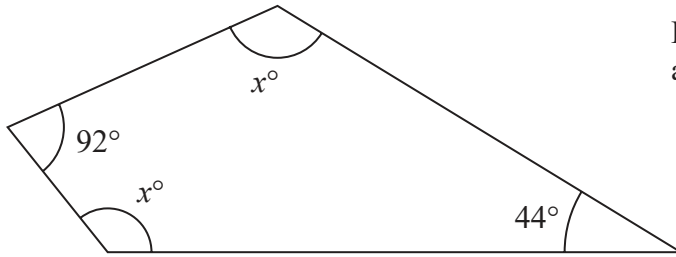

Diagram **NOT** accurately drawn

(i) Work out the value of x

$x = \dots\dots\dots$
(3)

(ii) Give a reason for your answer.

$\dots\dots\dots$
(1)

(Total for Question 9 is 4 marks)



P 6 8 7 2 8 A 0 9 2 8

10 Thabisa is organising a trip to the theatre.

The cost of a ticket for each adult is £11.75

The total cost of the tickets for 12 adults and 5 children is £181

Work out the cost of a ticket for each child.

£

(Total for Question 10 is 3 marks)

DO NOT WRITE IN THIS AREA

DO NOT WRITE IN THIS AREA

DO NOT WRITE IN THIS AREA



11 At school each week, Gabriella has to play a sport on Monday and a sport on Thursday.

The table shows the sports from which she can choose on Monday and the sports from which she can choose on Thursday.

Monday	Thursday
Tennis (T)	Volleyball (V)
Netball (N)	Badminton (B)
Hockey (H)	Tennis (T)

Write down all the possible combinations of these sports that Gabriella can play in one week.

.....

.....

.....

(Total for Question 11 is 2 marks)

12 Maria is going to make some flapjacks.

Here are four of the ingredients that she will use.

- 175 g butter
- 175 g syrup
- 175 g sugar
- 330 g oats

What percentage of these four ingredients is oats?
Give your answer correct to 3 significant figures.

..... %

(Total for Question 12 is 3 marks)



13 The diagram shows a solid wooden cuboid.

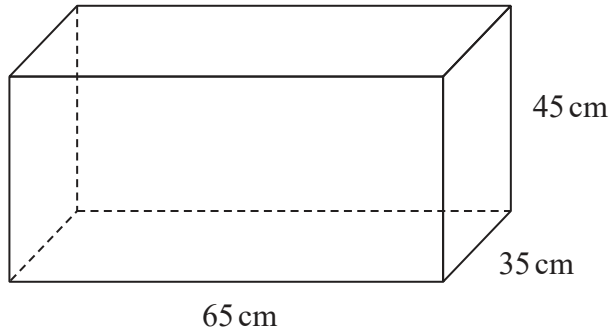

Diagram **NOT** accurately drawn

The cuboid measures 65 cm by 35 cm by 45 cm.

A machine cuts the cuboid to make cubes.
Each cube has edges of length 5 cm.

Work out the maximum number of cubes that can be made from the cuboid.

(Total for Question 13 is 3 marks)

DO NOT WRITE IN THIS AREA

DO NOT WRITE IN THIS AREA

DO NOT WRITE IN THIS AREA



DO NOT WRITE IN THIS AREA

DO NOT WRITE IN THIS AREA

DO NOT WRITE IN THIS AREA

14 Anjali, Ravina and Sandeep were the three candidates in an election.

Heidi draws a pie chart for the number of votes received by each of the three candidates.

The angle in the pie chart for the number of votes received by Anjali is 90°

The angle in the pie chart for the number of votes received by Ravina is 160°

Ravina received 400 votes.

Work out the number of votes Sandeep received.

.....
(Total for Question 14 is 3 marks)



15 (a) Solve $5c = 15$

$$c = \dots\dots\dots (1)$$

(b) Expand $x(8 - x)$

$$\dots\dots\dots (1)$$

$$T = 5m - 6n$$

(c) Work out the value of T when $m = 4.2$ and $n = -2.5$

$$T = \dots\dots\dots (2)$$

(d) Make g the subject of $k = 2g + t$

$$\dots\dots\dots (2)$$

(Total for Question 15 is 6 marks)



DO NOT WRITE IN THIS AREA

DO NOT WRITE IN THIS AREA

DO NOT WRITE IN THIS AREA

16 (a) Show that $\frac{3}{8} \div \frac{27}{32} = \frac{4}{9}$

(2)

(b) Show that $\frac{5}{6} - \frac{3}{8} = \frac{11}{24}$

(2)

(Total for Question 16 is 4 marks)



17 The accurate scale drawing shows the position of a college C and a train station S

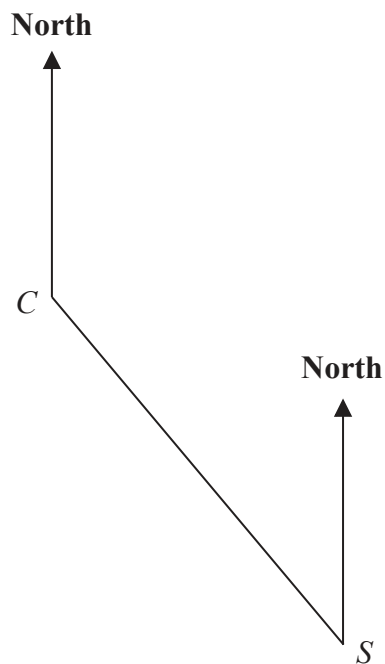

Scale: 1 cm represents 500 m

(a) Find the bearing of S from C

.....
(1)

For Charles,
1 step = 0.44 m

(b) Work out the number of steps Charles walks as he goes in a straight line from the college to the train station.
Give your answer correct to the nearest whole number of steps.

.....
(4)

(Total for Question 17 is 5 marks)



- 18 A tin contains tea bags with a choice of four different flavours of tea. The four flavours of tea are Assam or Darjeeling or Nilgiri or Rize.

Sara takes at random a tea bag from the tin.

The table shows each of the probabilities that the flavour of the tea Sara takes is Assam or Darjeeling or Rize.

Flavour of tea	Assam	Darjeeling	Nilgiri	Rize
Probability	0.38	0.24		0.16

- (a) Work out the probability that the flavour of the tea Sara takes is Nilgiri.

.....
(2)

- (b) Work out the probability that the flavour of the tea Sara takes is either Darjeeling or Rize.

.....
(2)

(Total for Question 18 is 4 marks)



19 Mary saves for a holiday each year.

In 2020 she saved a total of \$720

In 2021, each month she saved \$78

The total amount Mary saved in 2021 was $P\%$ more than the total she saved in 2020

(a) Work out the value of P

DO NOT WRITE IN THIS AREA

DO NOT WRITE IN THIS AREA

DO NOT WRITE IN THIS AREA

.....
(4)



Roberto is going to go on holiday.

He has two coupons that will save him money on his holiday.

Coupon A

18% off the cost of the accommodation

Coupon B

12.5% off the total cost of the accommodation **and** the flights

For Roberto's holiday

the cost of the accommodation is \$1600

the cost of the flights is \$800

Roberto can only use one of the coupons.

He wants to save as much money as he can.

- (b) Which of the two coupons, **A** or **B**, should he use?
Show your working clearly.

(3)

(Total for Question 19 is 7 marks)



20 (a) Solve $4y + 5 > 12$

.....
(2)

(b) Solve $6x - 5 = \frac{4x - 7}{2}$

Show clear algebraic working.

$x =$
(3)

(Total for Question 20 is 5 marks)



DO NOT WRITE IN THIS AREA

DO NOT WRITE IN THIS AREA

DO NOT WRITE IN THIS AREA

21 The diagram shows a regular octagon $ABCDEFGH$ and a regular pentagon $ABIJK$

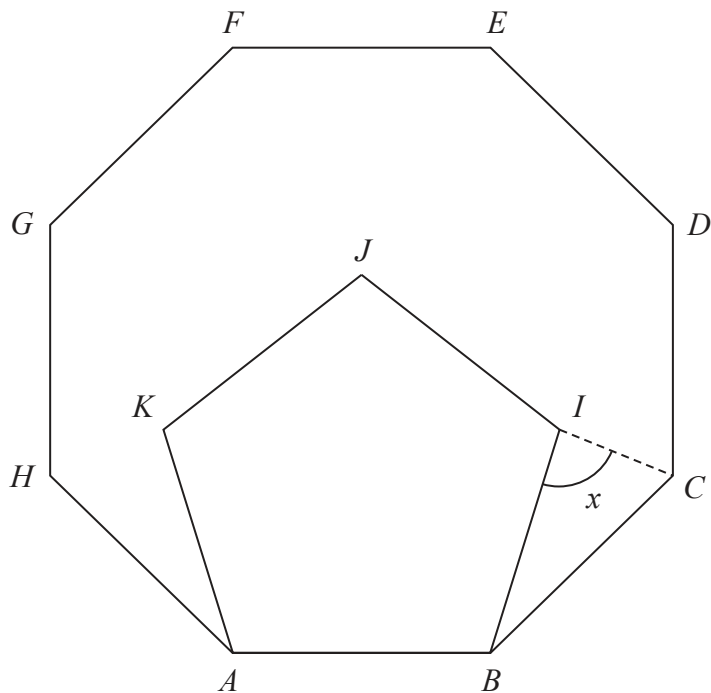

Diagram NOT accurately drawn

Work out the size of the angle x

(Total for Question 21 is 4 marks)



P 6 8 7 2 8 A 0 2 1 2 8

DO NOT WRITE IN THIS AREA

DO NOT WRITE IN THIS AREA

DO NOT WRITE IN THIS AREA

22 Shane invests 7200 dollars for 3 years in a savings account.
He gets 2.5% per year compound interest.

How much money will Shane have in his savings account at the end of 3 years?
Give your answer to the nearest dollar.

..... dollars

(Total for Question 22 is 3 marks)



23 (a) Write down the value of x^0

.....
(1)

Given that $2^{-3} \times 2^9 = 2^n$

(b) find the value of n

$n =$
(1)

Given that $\frac{7^{206} \times 7^m}{7^{214}} = 7^{-3}$

(c) find the value of m

$m =$
(2)

(Total for Question 23 is 4 marks)



- 24 (a) Write down an equation of the straight line with gradient -3 and which passes through the point with coordinates $(0, 5)$

.....
(2)

- (b) Show, by shading on the grid, the region defined by **all three** of the inequalities

$$x \leq 6$$

$$y \geq 2$$

$$y \leq x + 1$$

Label the region **R**

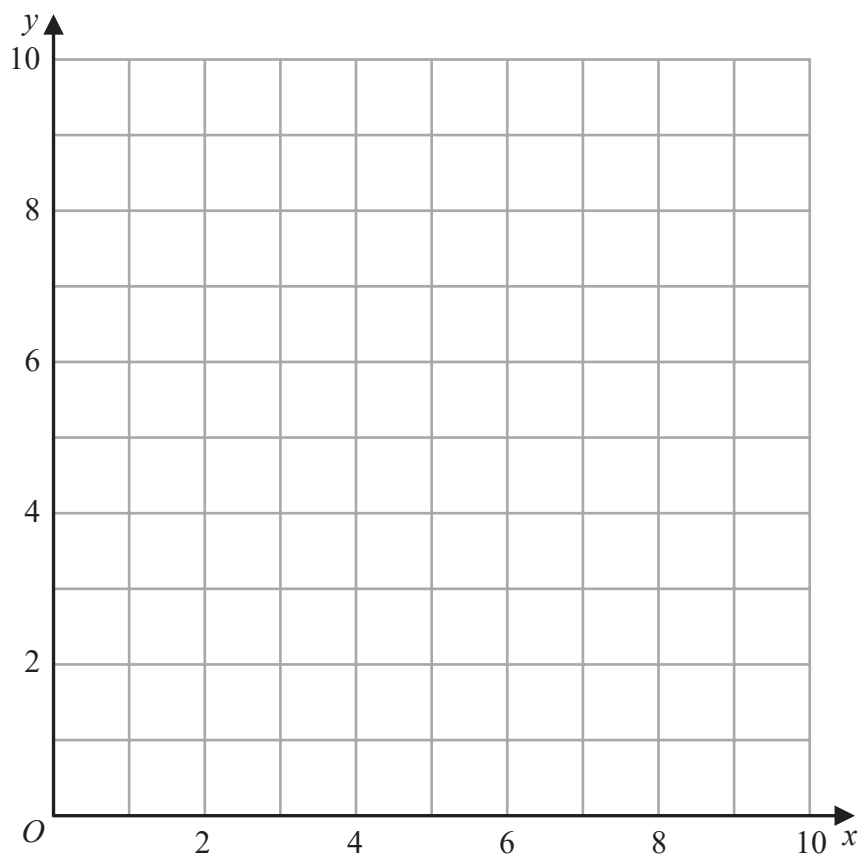

(3)

(Total for Question 24 is 5 marks)



25 A scientist is investigating the weight of 50 tigers.

Here is some information about these tigers.

	Type of tiger	
	Siberian	Bengal
Number of tigers	22	28
Mean weight of tigers (kg)	260	

The mean weight of all 50 tigers is 218 kg

Work out the mean weight of the Bengal tigers.

..... kg

(Total for Question 25 is 3 marks)



26 In the diagram, ABC is a right-angled triangle and DEF is a semicircular arc.

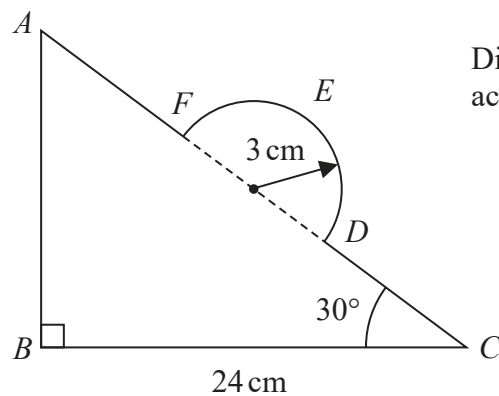

Diagram **NOT** accurately drawn

In triangle ABC

$$BC = 24 \text{ cm}$$

$$\text{angle } ABC = 90^\circ$$

$$\text{angle } BCA = 30^\circ$$

The points D and F lie on AC so that DF is the diameter of the semicircular arc DEF
 The radius of the semicircular arc is 3 cm.

Work out the length of $AFEDC$

Give your answer correct to 2 significant figures.

DO NOT WRITE IN THIS AREA

DO NOT WRITE IN THIS AREA

DO NOT WRITE IN THIS AREA



DO NOT WRITE IN THIS AREA

DO NOT WRITE IN THIS AREA

DO NOT WRITE IN THIS AREA

..... cm

(Total for Question 26 is 5 marks)

TOTAL FOR PAPER IS 100 MARKS



P 6 8 7 2 8 A 0 2 7 2 8

DO NOT WRITE IN THIS AREA

DO NOT WRITE IN THIS AREA

DO NOT WRITE IN THIS AREA

BLANK PAGE

